

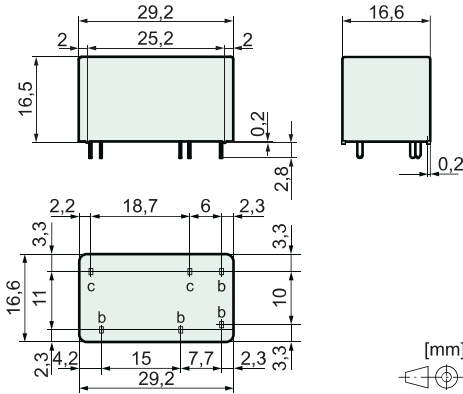

Features

- Relay with forcibly guided contacts according to IEC 61810-3
- Application type A
- Protective separation (see insulation data)
- Suitable for print mounting
- Small design
- Contact assembly
SIS112: 1 NO + 1 NC

Dimensions



Pin dimension b	1,0 x 0,3 mm
Pin dimension c	1,0 x 0,4 mm
Recommended drilling on PCB	Ø 1,3 mm

Coil data at 20 °C

Nominal power (typ.)	0,27 W
Holding power (typ.)	0,08 W
Coil limit temperature	120 °C

Nominal voltage (VDC)	Min. Pick-up voltage (VDC)	Min. Drop-out voltage (VDC)	Nominal current (mA)	Resistance (Ohm)
5,0	3,5	0,5	55	91 (1 ± 10 %)
12,0	8,4	1,2	23	520 (1 ± 10 %)
18,0	12,6	1,8	15	1180 (1 ± 10 %)
24,0	16,8	2,4	11	2100 (1 ± 10 %)
48,0	33,6	4,8	6	8350 (1 ± 13 %)
60,0	42,0	6,0	5	13100 (1 ± 15 %)

Excitation voltage range

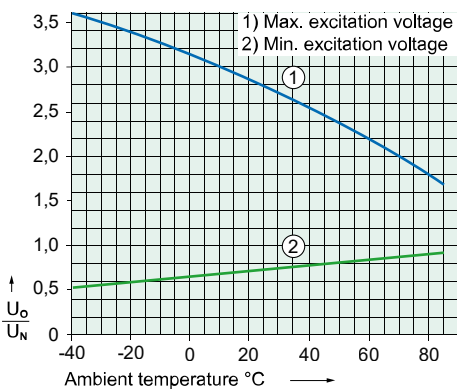

Test conditions:

- Graph 1: Contact current 4 A MAX
- Graph 2: without previous operation
- Free-standing relay on PCB
- Duty cycle 100%

Contact data

Contact material	AgCuNi + 0,2, ..., 0,4 µm Au
Type of contact	Single contact with notched crown
Rated switching power	1500 VA
250 V / 6 A / AC-1 (max.)	
Electr. life time (0,1 Hz, rel. duty cycle 10%)	90 000
Inrush current	30 A for 20 ms
Switching voltage range	5, ..., 250 V DC / AC
Switching current range*	3 mA, ..., 6 A
Switching power range*	40 mW, ..., 1500 W (VA)
Contact resistance as new (max.)	100 mΩ
Short circuit resistance of contacts**	1 000 A
with pre-fuse	SCPD 6 A gG / gL (fuse)

* Reference values ** Prospective short-circuit current

Electrical life (NO contacts)

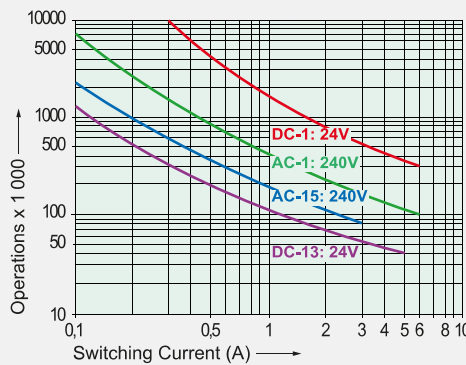

Switching capacity (IEC 61810-1)

AC-1:	240 V / 6 A MAX
AC-15:	240 V / 3 A MAX
DC-1:	24 V / 6 A MAX
DC-13:	24 V / 5 A / 0,1 Hz MAX

Switching capacity (UL 508)	B300, R300
Continuous current per contact at load of:	
1 contact	6 A MAX

Contact load limit curve (DC)

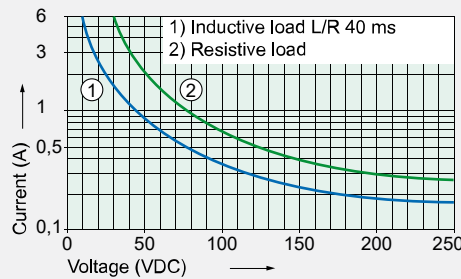

Circuit diagram (top view)

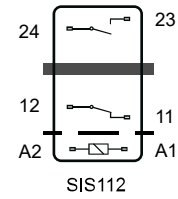

Insulation data

Rated insulation voltage (IEC 60664-1)	250 VAC
Basic insulation	4 mm
- Air and creepage distance (min.)	4 mm
- Test voltage	2500 V _{rms} / 1 min
Double or reinforced insulation	10 mm
- Air and creepage distance (min.)	10 mm
- Test voltage	5000 V _{rms} / 1 min
Open contact: Test voltage*	1500 V _{rms} / 1 min
Creepage resistance	CTI 175
Pollution degree	2
Overvoltage category	III
Insulation resistance (min.)	100 MΩ
- Test voltage	500 VDC

* Initial value

Mechanical data

Mechanical lifetime (min.)	10 x 10 ⁶ operations
Switching frequency (max.)	15 Hz
Response time (NO closed) (typ.)	10 ms
Drop-out time (NC closed) (typ.)*	3 ms
Bounce time (typ.)	NO: 2 ms / NC: 15 ms
Shock resistance (16 ms) (min.)	NO: 17g / NC: 7g
Vibration resistance (10-200 Hz) (min.)	NO: 7g / NC: 2g
Weight	approx. 18 g
Mounting position	any
Mounting distance (min.)	1 mm

* without coil wiring

Other data

Ambient temperature	-40 °C, ..., +85 °C
Thermal resistance	55 K / W
Protection class	RT III
Solder bath temperature	270 °C / 5 s
Test method (heating)	A (group assembly)
Approvals	cULus, TÜV
Flammability class	UL 94 V-0
UL File	E188953 Sec. 5

Options, Accessories

Mounting rail socket	SRD SIS3
Pin lengths for mounting rail socket	3,8 mm
Other pin lengths	possible
Other coil designs	possible
Coils accord. to EN 50155 (railway applications)	possible

Product key

SIS 1 1 2 24VDC XX

SIS	Type designation	
1	Number of contacts NO	
1	Number of contacts NC	
2	Connection technology	2 = Solder terminals
24VDC	Nominal coil voltage	
XX	Options	