

Features

- Relay with forcibly guided contacts according to IEC 61810-3
- Application type A
- Protective separation (see insulation data)
- Suitable for print mounting
- Contact assignment
SIM312: 3 NO + 1 NC, SIM222: 2 NO + 2 NC

Dimensions

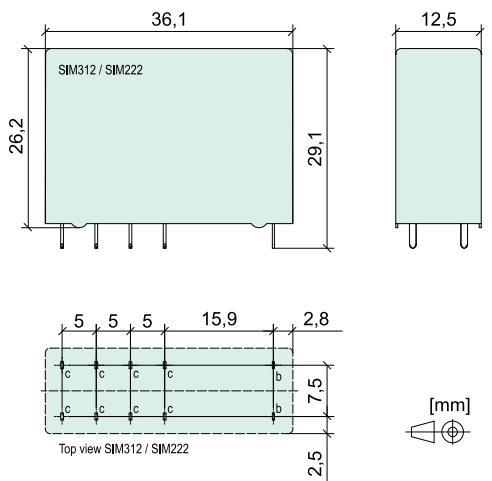

Pin dimension b	1,0 x 0,3 mm
Pin dimension c	1,0 x 0,4 mm
Recommended drilling on PCB	Ø 1,3 mm

Coil data at 20 °C

Nominal power (typ.)	1,0 W
Holding power (typ.)	0,29 W
Coil limit temperature	120 °C

Nominal voltage (VDC)	Min. Pick-up voltage (VDC)	Min. Drop-out voltage (VDC)	Nominal current (mA)	Resistance (Ohm)
5,0	3,8	0,5	182	28 (1 ± 10 %)
12,0	9,0	1,2	86	140 (1 ± 10 %)
18,0	13,5	1,8	55	330 (1 ± 10 %)
24,0	18,0	2,4	40	600 (1 ± 10 %)
48,0	36,0	4,8	21	2300 (1 ± 10 %)
60,0	45,0	6,0	17	3600 (1 ± 13 %)
110,0	82,5	11,0	9	12100 (1 ± 15 %)

Excitation voltage range

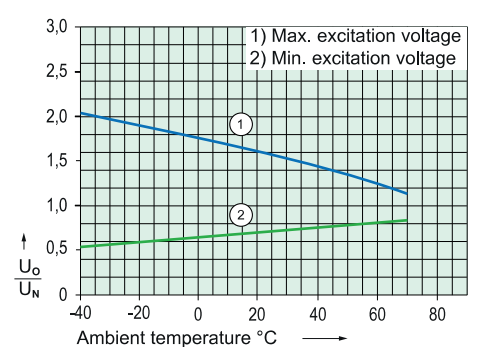

- Test conditions:
- Graph 1: Contact current 6 A MAX
 - Graph 2: without previous operation
 - Free-standing relay on PCB
 - Duty cycle 100%

Contact data

Contact material	AgSnO ₂ + 0,2, ..., 0,4 µm Au
Contact type	crown contact
Rated switching power	2000 VA
250 V / 8 A / AC-1 (max.)	
Electr. life time (0,1 Hz, rel. duty cycle 10%)	100 000
Inrush current	20 A for 20 ms
Switching voltage range	5, ..., 250 V DC / AC
Switching current range*	10 mA, ..., 8 A
Switching power range*	60 mW, ..., 2000 W (VA)
Contact resistance as new (max.)	100 mΩ
Short circuit resistance of contacts**	1000 A
with pre-fuse	SCPD 10 A gG / gL (fuse)

* Reference values ** Prospective short-circuit current

Electrical life (NO contacts)

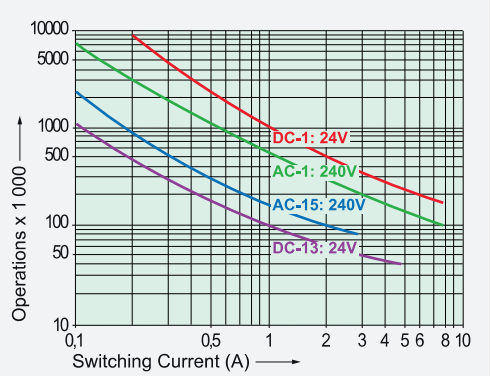

Switching capacity (IEC 61810-1)	
AC-1:	240 V / 8 A MAX
AC-15:	240 V / 3 A MAX
DC-1:	24 V / 8 A MAX
DC-13:	24 V / 6 A / 0,1 Hz MAX

Switching capacity (UL 508)	C150, R300
Continuous current per contact at load of:	
1 or 2 contacts	8 A MAX
3 contacts	6 A MAX

Contact load limit curve (DC)

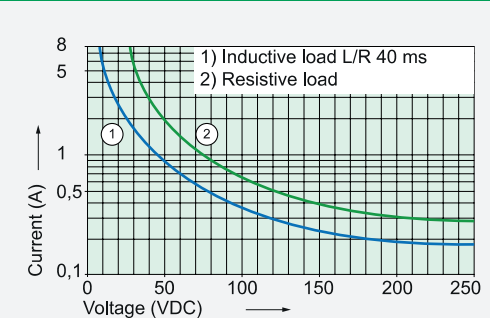

Circuit diagram (top view)

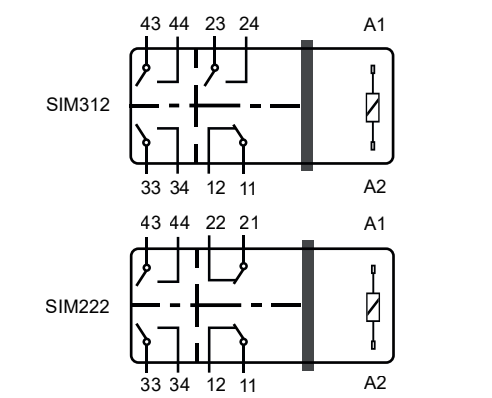

Insulation data

Rated insulation voltage (IEC 60664-1)	250 VAC
Basic insulation	— — — — —
- Air and creepage distance (min.)	4 mm
- Test voltage	2500 V _{rms} / 1 min
Double or reinforced insulation	— — — — —
- Air and creepage distance (min.)	5,5 mm
- Test voltage	4000 V _{rms} / 1 min
Double or reinforced insulation	— — — — —
- Air and creepage distance (min.)	14 mm
- Test voltage	5000 V _{rms} / 1 min
Open contact: Test voltage*	1500 V _{rms} / 1 min
Creepage resistance	CTI 250
Pollution degree	2
Overvoltage category	III
Insulation resistance (min.)	100 MΩ
- Test voltage	500 VDC

* Initial value

Mechanical data

Endurance (min.)	10 x 10 ⁶ operations
Switching frequency (max.)	15 Hz
Response time (NO closed) (typ.)	8 ms
Drop-out time (NC closed) (typ.)*	4 ms
Bounce time (typ.)	NO: 6 ms / NC: 12 ms
Shock resistance (16 ms) (min.)	NO: 10g / NC: 2,5g
Vibration resistance (10-200 Hz) (min.)	NO: 10g / NC: 1g
Weight	approx. 25 g
Mounting position	any
Mounting distance (min.)	5 mm

* without coil wiring

Other data

Ambient temperature	-40 °C, ..., +70 °C
Thermal resistance	50 K / W
Protection class	RT II
Solder bath temperature	270 °C / 5 s
Test method (heating)	A (group assembly)
Approvals	cULus, TÜV
Flammability class	UL 94 V-0
UL File	E188953 Sec. 3

Options, Accessories

Mounting rail socket	SRD SIM4
PCB socket	SRP SIM4
Other coil designs	possible

Product key

SIM	3	1	2	24VDC	XX
SIM	Type designation				
3	Number of contacts NO				
1	Number of contacts NC				
2	Connection technology	2 = Solder terminals			
24VDC	Nominal coil voltage				
XX	Options				